

A. YEFIMOV, YU. ROMASHOV, V. KAVERTSEV

**ESTIMATING WORKABILITY OF STEAM BOILERS SUPERHEATERS
CONSIDERING WITH THE HIGH-TEMPERATURE CREEP
AND UNIFORM CHEMICAL CORROSION**

It is proposed theoretical estimating workability of steam boilers superheaters on the base of considering the influence of a high-temperature uniform chemical corrosion on of a high-temperature creep of superheater pipes on account of stresses redistributions the pipes walls due to their thickness decreasing. The high-temperature uniform chemical corrosion is presented by the well-known time and temperature dependences of the height of damaged material. The high-temperature creep is considered using the well-known incremental-type theory taking into account the Cachanov-Rabotnov scalar damage parameter. It is proposed the mathematical model of state of superheaters pipes in the form of initial-boundary-value problem in the domain with the moving boundary. The differential equations, initial and boundary conditions of that problem are corresponded to the well-known in the theory of high-temperature creep. Moving of the boundary is corresponded to the well-known time dependence of the height of damaged material due to the high-temperature uniform chemical corrosion. Although, the used theory of creep and the used regularities of uniform corrosion are well-known separately, considering the influence of uniform corrosion on the creep is the complicated problem due to the moving boundary in the corresponded initial-boundary-value problem. It is shown, that the spatial variable replacement allows to reduce the proposed initial-boundary-value problem with the moving boundary to the initial-boundary-value problem with the fixed normed boundary, that allows to simplify numerical solving of the considered problem. The method of lines is discussed for solving the initial-boundary-value problem, representing the mathematical model of the state of pipes of superheaters.

Key words: superheater, steam boiler, pipe, life time, uniform corrosion, high-temperature creep, damage parameter, initial-boundary-value problem, moving boundary, method of lines.

**О. В. ЄФІМОВ, Ю. В. РОМАШОВ, В. Л. КАВЕРЦЕВ
ОЦІНКА ПРАЦЕЗДАТНОСТІ ПАРОПЕРЕГРІВАЧІВ ПАРОВИХ КОТЛІВ
З УРАХУВАННЯМ ВИСОКОТЕМПЕРАТУРНОЇ ПОВЗУЧОСТІ
І РІВНОМІРНОЇ ХІМІЧНОЇ КОРРОЗІИ**

Пропонується теоретична оцінка працездатності пароперегрівачів парових котлів на основі врахування впливу високотемпературної рівномірної хімічної корозії на високотемпературну повзучість труб пароперегрівача через перерозподіл напружень стінок труб через зменшення їх товщини. Запропоновано математичну модель стану труб пароперегрівачів у вигляді початково-крайової задачі з рухомою границею. Показано, що заміна просторової змінної дозволяє звести запропоновану початково-крайову задачу з рухомою границею до початково-крайової задачі з фіксованою границею, що дозволяє спростити чисельне рішення даної задачі.

Ключові слова: пароперегрівач, паровий котел, труба, ресурс, рівномірна корозія, високотемпературна повзучість, параметр пошкоджуваності, початково-крайова задача, рухома границя, метод прямих.

**А. В. ЕФИМОВ, Ю. В. РОМАШОВ, В. Л. КАВЕРЦЕВ
ОЦЕНКА РАБОТОСПОСОБНОСТИ ПЕРЕГРЕВАТЕЛЕЙ ПАРОВЫХ КОТЛОВ
С УЧЕТОМ ВИСОКОТЕМПЕРАТУРНОЙ ПОЛЗУЧЕСТИ
И РАВНОМЕРНОЙ ХИМИЧЕСКОЙ КОРРОЗИИ**

Предлагается теоретическая оценка работоспособности пароперегревателей паровых котлов на основе учета влияния высокотемпературной равномерной химической коррозии на высокотемпературную ползучесть труб пароперегревателя из-за перераспределения напряжений стенок труб из-за уменьшения их толщины. Предложена математическая модель состояния труб пароперегревателей в виде начально-краевой задачи в области с подвижной границей. Показано, что замена пространственной переменной позволяет свести предложенную начально-краевую задачу с подвижной границей к начально-краевой задаче с фиксированной нормированной границей, что позволяет упростить численное решение рассматриваемой задачи.

Ключевые слова: пароперегреватель, паровой котел, труба, ресурс, равномерная коррозия, высокотемпературная ползучесть, параметр повреждаемости, начально-краевая задача, подвижная граница, метод прямых.

Introduction

It is well-known, that workability of the steam superheaters of boilers is significantly limited on account of the most complicated operating conditions due to the highest internal pressures and temperatures firstly.

The heat exchanges pipes are the principal parts of the steam superheaters of boilers [1]. These pipes of the superheater are located in the flow of high-temperature combustion gaseous products and the water vapour is heated while it moving inside that pipes. The highest pressures of the water vapour and

temperatures of this vapour and combustion products, heating the vapour, lead to the damages due to the creep of pipes of steam superheaters. Besides, and the highest chemical reactivity of the combustion products, heating the pipes, leads to the significant damages due to the corrosion of steam superheaters of boilers. Thus, workability of steam superheaters of boilers is the one of principal problem in thermal power industry and engineering. Due to these circumstances, there are a lot of publications, connecting with workability of steam superheaters of boilers [2–4], which make actual the theme of this article, which deals with superheater workability too.

© A. Yefimov, Yu. Romashov, V. Kavertsev, 2019

Purposes of the article

The high-temperature creep and uniform chemical corrosion in combustion products and their influences on limiting the workability of steam superheaters of boilers are relatively fully researched separately each other as wrote in [5, 6] for example. At the same time, the high-temperature creep and the uniform corrosion are presented simultaneously during superheaters operating, and the workability assessments considering separately the creep only and the corrosion only can be noticeable different from the actual workability of steam superheaters. Really, the uniform corrosion leads to decreasing the thickness of the wall of pipes of steam superheaters, and as the results of this it lead to the increasing of the internal mechanical stresses as clearly understood from well-known fundamentals of the strength of materials and the theory of elasticity [7, 8]. At the same time, the rate of creep is significantly depended on the mechanical stresses at the given temperature and due to the nonlinear dependence between the rate of creep and the stress the relative small increasing of the stress can lead to noticeable increasing the rate of the creep [9, 10]. Thus, the uniform corrosion can noticeably accelerate the rate of the creep in account of the stresses increasing due to the thickness decreasing of the wall of superheaters pipes and it is necessary to have the assessments for magnitudes of that acceleration and their influences on workability of superheaters. Thus, the purpose of this article is developing the approaches to estimating workability of the steam superheaters of boilers considering with influencing the uniform high-temperature chemical corrosion on the damaging due to the high-temperature creep of superheaters pipes.

Mathematical model of superheater's pipes, considering the creep and uniform corrosion

The typical steam superheater of a boiler is a lot of heat exchanging pipes, which are hanged in the boiler's gas flue, so that the heated steam is moved inside these pipes, but the heating combustion gaseous products are moved on the outside these pipes, as shown on the fig. 1-a.

The average length l of the straight fragment of the pipes is significantly greater than the transverse sizes, limited by the external radius of the pipes. Due this circumstance the states of the pipers are almost similar at the cross-sections far from the edges of the pipes. Thus, to define the state of the pipe at the central cross-sections it is possible to use the well-known assumptions of the plane problem, widely used in theory of elasticity and in the theory of creep to simplify the problems [7, 9], and to consider further the state of only the central cross-section (fig. 1-b) of the pipe of a superheater.

It is naturally to assume that the pressure p of the heated steam, moving inside the pipe, is similar in

all circumferential directions (fig. 1-b). Corresponding with purposes of this article, it is suitable to neglect the all circumferential distributions of the state of the pipe, because it will allow to simplify significantly the mathematical formulation of the problem without losing the opportunities for researching.

The high-temperature creep will be considered further on the base of the incremental-type creep theory with the Cachanov-Rabotnov scalar damage parameter, which allowing to define the rupture time of the pipe, limiting the workability of a superheater.

Results of the high-temperature uniform chemical corrosion will be imagined as decreasing the external radius of the pipe on the magnitude [11]:

$$\kappa(t; T) = C(T) \cdot t^{D(T)}, \quad (1)$$

where κ is the depth of corrosion-damaged layer on main metal (fig. 1-b); t is the time and T is the temperature; $C(T)$ and $D(T)$ are the functions, corresponded to the given structural material of the combustion products of the given fuel, which can be estimated as the results of experimental researching [11].

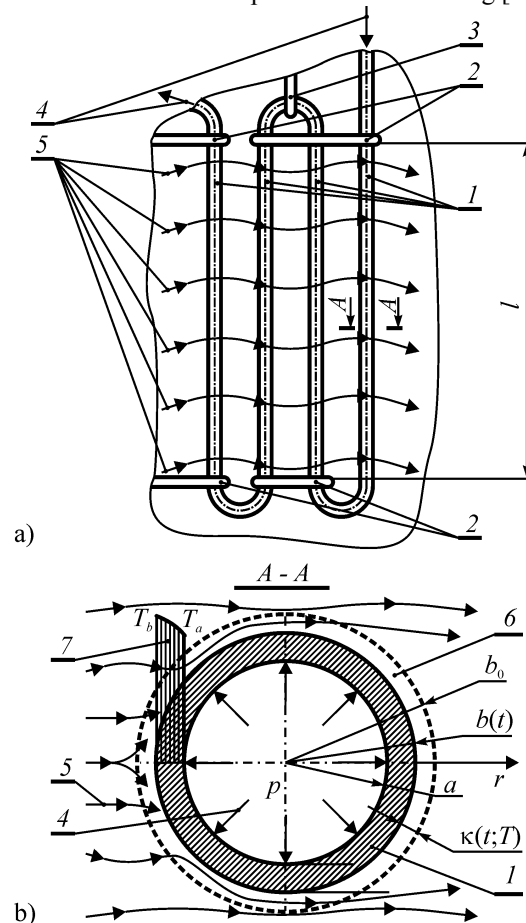

Fig. 1 – The fragment of a typical superheater (a) and the cross-section (b) of its pipe:

- 1 – pipes; 2 – fixing parts; 3 – suspension rod;
- 4 – moving steam; 5 – moving combustion products;
- 6 – corrosion damaged layer;
- 7 – diagram of the temperature in the pipe's wall

The uniform corrosion of the pipe of superheaters from the steam side is neglected, so that the internal radius a of the pipe is the constant (see fig. 1-b). At the same time, the external radius of the pipe is changed during the operating time, and this changing can be represented using the relation (1) in the form:

$$b(t) = b_0 - \kappa(t; T_b), \quad (2)$$

where $b(t)$ is the external radius of the pipe at the time moment t , but b_0 is the external radius of the pipe at the time moment $t = 0$; T_b is the temperature of the pipe at its external radius (see fig. 1-b).

The temperature field in the wall of the pipe can be chose corresponding to the solution of stationary heat conduction in the axial-symmetrical cylinder considering the relation (2) in this solution as:

$$T(r, t) = T_b - (T_b - T_a) \frac{\ln(r/b(t))}{\ln(a/b(t))}, \quad (3)$$

where T_a is the temperature of the pipe at its internal radius (see fig. 1-b).

Magnitudes T_a and T_b of the temperatures at the internal and external surfaces of the pipe of the superheater can be estimated from heat transfer analysis in the steam boiler independently from the pipe workability researching.

Considering the noted above assumptions, the mathematical model of the state of the pipe of a steam superheater of a boiler is proposed as follows:

$$-\frac{1}{E}\sigma_r + \frac{\nu}{E}\sigma_\theta + \frac{\partial u}{\partial r} = \alpha(T(r, t) - T_0) + c_r - \frac{\nu}{E}\sigma_z, \quad (4)$$

$$\frac{\nu}{E}\sigma_r - \frac{1}{E}\sigma_\theta + \frac{u}{r} = \alpha(T(r, t) - T_0) + c_\theta - \frac{\nu}{E}\sigma_z,$$

$$\frac{\partial \sigma_r}{\partial r} + \frac{\sigma_r - \sigma_\theta}{r} = 0, \quad (4)$$

$$\sigma_r|_{r=a} = -p, \sigma_r|_{r=b(t)} = 0, \quad (5)$$

$$\frac{\partial c_r}{\partial t} = \frac{f_c(\omega, \sigma_{eq}; T(r, t))}{2\sigma_{eq}} (2\sigma_r - \sigma_\theta - \sigma_z),$$

$$\frac{\partial c_\theta}{\partial t} = \frac{f_c(\omega, \sigma_{eq}; T(r, t))}{2\sigma_{eq}} (2\sigma_\theta - \sigma_r - \sigma_z),$$

$$\frac{\partial \omega}{\partial t} = f_\omega(\omega, \sigma_{eq}; T(r, t)), \quad (6)$$

$$c_r|_{t=0} = 0, c_\theta|_{t=0} = 0, \omega|_{t=0} = 0, \quad (7)$$

$$a \leq r \leq b(t), \quad (8)$$

where r is the radial coordinate (see fig. 1-b); E , ν and α are the average in corresponding temperature interval magnitudes of the Young's module, Poisson's ratio and the thermal expansion of the structural material of the pipe; σ_r , σ_θ and

$$\sigma_z = p \frac{a^2}{b^2(t) - a^2}$$

are the radial, circumferential and axial stresses in the pipe; u is the radial displacement of the pipe;

$T_0 = 293\text{K}$ is the temperature of the naturally unloaded state; c_r and c_θ are the radial and circumferential creep deformations of the pipe; ω is the Cachanov-Rabotnov damage parameter;

$$\sigma_{eq} = \frac{1}{\sqrt{2}} \sqrt{(\sigma_r - \sigma_\theta)^2 + (\sigma_\theta - \sigma_z)^2 + (\sigma_z - \sigma_r)^2}$$

is the equivalent stress; $f_c(\omega, \sigma_{eq}; T)$ is the creep equivalent deformation velocity and $f_\omega(\omega, \sigma_{eq}; T)$ is the damage parameter velocity, which all can be established for the given structural material using creep and long-term strength curves at given temperatures.

Differential equations (4) and boundary conditions (5) represent the mathematical model of the stress-strain state of the pipe for the given temperature and the given creep deformations. Differential equations (6) and initial conditions (5) represent the mathematical model of growth the creep deformations and the permanent damages in the pipe. The relation (8) defines the domain of the pipe cross-section with the moving external surface. The influence of the uniform corrosion on the creep and damages the pipe is presented in mathematical formulation (4)–(8) through the time depended external radius (2) of the pipe, which is defined using the model of uniform corrosion in the form (1).

Numerical analysis the state of the pipe considering the creep and the uniform corrosion

The most main difficulties in solving the initial-boundary-value problem (4)–(7) are due to the moving boundary (8). Really, for the fixed boundary, when the external radius is not depends on the time and is the given constant, it is possible to solve the problem (4)–(7) of the theory of creep by using the Galerkin's method [12] or by the more effective method of lines [13], because the equations (4), (6) can be discretized once for the given fixed domain and this discretization can be used further during integrating on the time as wrote in [12, 13]. In the case of the moving boundary (8), the equations (4), (6) at some moment of the time are defined in the current domain, corresponded to the moving boundary at that same moment of the time. Thus, during integrating on the time it is necessary to rebuild discretization of the equations (4) and (6) for each current moment of the time.

For solving the initial-boundary-value problem (4)–(7) with the moving boundary (8) it is suitable to use the variable replacement:

$$\rho = \frac{r - a}{b(t) - a}. \quad (9)$$

where ρ is the new spatial variable for further using instead the radial coordinate r .

As follows from the double inequalities (8), defining the domain with the moving boundary, considering the definition (9) the introduced new spatial variable is changed in the constant limits:

$$0 \leq \rho \leq 1, \quad (10)$$

where $\rho = 0$ and $\rho = 1$ are the values, corresponding to the internal and external side-surfaces of the pipe of a steam superheater.

Using the definition (9) of the new spatial variable, it is possible to represent the radial coordinate as

$$r = a(1 - \rho) + \rho b(t). \quad (11)$$

Relations (9) and (11) allow to reduce the equations (4) with the boundary conditions (5) as well as the equations (6) to the form

$$-\frac{1}{E}\sigma_r + \frac{\nu}{E}\sigma_\theta + \frac{1}{b(t)-a}\frac{\partial u}{\partial \rho} =$$

$$= \alpha(T(\rho, t) - T_0) + c_r - \frac{\nu}{E}\sigma_z,$$

$$\frac{\nu}{E}\sigma_r - \frac{1}{E}\sigma_\theta + \frac{u}{a(1-\rho) + \rho b(t)} =$$

$$= \alpha(T(\rho, t) - T_0) + c_\theta - \frac{\nu}{E}\sigma_z,$$

$$\frac{1}{b(t)-a}\frac{\partial \sigma_r}{\partial \rho} + \frac{\sigma_r - \sigma_\theta}{a(1-\rho) + \rho b(t)} = 0, \quad (12)$$

$$\sigma_r|_{\rho=0} = -p, \quad \sigma_r|_{\rho=1} = 0. \quad (13)$$

$$\frac{\partial c_r}{\partial t} = \frac{f_c(\omega, \sigma_{eq}; T(\rho, t))}{2\sigma_{eq}}(2\sigma_r - \sigma_\theta - \sigma_z),$$

$$\frac{\partial c_\theta}{\partial t} = \frac{f_c(\omega, \sigma_{eq}; T(\rho, t))}{2\sigma_{eq}}(2\sigma_\theta - \sigma_r - \sigma_z),$$

$$\frac{\partial \omega}{\partial t} = f_\omega(\omega, \sigma_{eq}; T(\rho, t)). \quad (14)$$

Thus, the initial-boundary-value problem (4)–(7) with the moving boundary (8) is reduced to the initial-boundary-value problem (12)–(14) (7) in the domain (10) with the fixed boundaries, but the equations (12) have the time dependent coefficients instead the constant coefficients in the equations (4).

For solving the initial-boundary-value problem (12)–(14), (7) it is advisable to use the method of lines, as wrote in [13, 14]. To represent this approach it is suitable to represent the initial-boundary-value problem (12)–(14), (7) using the operator form:

$$\mathbf{A}^{(1)}(\rho, t, \mathbf{u}^{(1)}) + \mathbf{A}^{(2)}(\mathbf{u}^{(2)}) = \mathbf{f}^{(1)}(\rho, t), \quad (15)$$

$$\mathbf{B}_0^{(1)}(t, \mathbf{u}^{(1)}) = \mathbf{p}_0^{(1)}, \quad \mathbf{B}_1^{(1)}(t, \mathbf{u}^{(1)}) = \mathbf{p}_1^{(1)}, \quad (16)$$

$$\frac{\partial \mathbf{u}^{(2)}}{\partial t} = \mathbf{f}^{(2)}(\rho, t, \mathbf{u}^{(2)}; \mathbf{u}^{(1)}), \quad (17)$$

$$\mathbf{u}^{(2)}|_{t=0} = 0, \quad (18)$$

where $\mathbf{u}^{(1)}$ is the vector, including the stresses and displacement; $\mathbf{u}^{(2)}$ is the vector, including the creep deformations and the Cachanov-Rabotnov damage parameter; $\mathbf{A}^{(1)}(\rho, t, \bullet)$, $\mathbf{A}^{(2)}(\bullet)$ and $\mathbf{f}^{(1)}(\rho, t)$ are the operators and the vector-function, representing the equations (12) at the points $0 < \rho < 1$; $\mathbf{B}_0^{(1)}(t, \bullet)$ and

$\mathbf{p}_0^{(1)}$ are the operator and the vector, representing some of the equations (12) and the boundary conditions (13) at the point $\rho = 0$; $\mathbf{B}_1^{(1)}(t, \bullet)$ and $\mathbf{p}_1^{(1)}$ are the operator and the vector, representing some of the equations (12) and the boundary conditions (13) at the point $\rho = 1$; $\mathbf{f}^{(2)}(\rho, t, \bullet, \bullet)$ is the vector-function of vector two vector arguments, representing the equations (14) at the points $0 \leq \rho \leq 1$.

Following the method of lines, instead the vectors $\mathbf{u}^{(1)}$ and $\mathbf{u}^{(2)}$ in all points of spatial domain (10) these vectors will be considered in nodes only, representing some finite number of the points of the domain (10). These nodes are had the coordinates:

$$\rho_k = k \cdot \Delta\rho, \quad k = 0, 1, 2, \dots, n, \quad (19)$$

where n is the number of the nodes; $\Delta\rho = 1/n$ is the step of the grid; grid is imagined as the set of all nodes.

The nodal vectors $\mathbf{u}^{(1)}$ and $\mathbf{u}^{(2)}$ at the grid (19) nodes can be represented using the corresponding vectors $\mathbf{u}_n^{(1)}$ and $\mathbf{u}_n^{(2)}$. Using well-known finite differences technique, it is possible to represent the equations (15) considering with the boundary conditions (16) in the terms of the nodal vectors as follows:

$$[\mathbf{A}_n^{(1)}(t)] \cdot \mathbf{u}_n^{(1)} + [\mathbf{A}_n^{(2)}] \cdot \mathbf{u}_n^{(2)} = \mathbf{f}_n^{(1)}(t), \quad (20)$$

where $[\mathbf{A}_n^{(1)}(t)]$ is the some matrix function of the time; $[\mathbf{A}_n^{(2)}]$ is the some matrix; $\mathbf{f}_n^{(1)}(t)$ is the some vector function of the time.

The differential equations (17) with the initial conditions (18)

$$\frac{\partial \mathbf{u}_n^{(2)}}{\partial t} = \mathbf{f}_n^{(2)}(t, \mathbf{u}_n^{(2)}; \mathbf{u}_n^{(1)}) \Big|_{t=0} = 0, \quad (21)$$

where $\mathbf{f}_n^{(2)}(t, \bullet, \bullet)$ is the some vector function of the time and two vectors.

Using the relation (20), which represents the discretised boundary-value problem (15), (16) for a given vector $\mathbf{u}^{(2)}$, it is possible by solving the corresponding linear equations system to find the following vector function of the time and the vector argument:

$$\mathbf{u}_n^{(1)}(t, \mathbf{u}_n^{(2)}) = [\mathbf{A}_n^{(1)}(t)]^{-1} \cdot (\mathbf{f}_n^{(1)}(t) - [\mathbf{A}_n^{(2)}] \cdot \mathbf{u}_n^{(2)}). \quad (22)$$

The vector function (23) gives the possibilities for excluding the vector $\mathbf{u}_n^{(1)}$ from relations (21) and allows to represent (21) as follows:

$$\frac{\partial \mathbf{u}_n^{(2)}}{\partial t} = \mathbf{f}_n^{(2)}(t, \mathbf{u}_n^{(2)}; \mathbf{u}_n^{(1)}(t, \mathbf{u}_n^{(2)})) \Big|_{t=0} = 0. \quad (23)$$

Actually, the relations (23) are representing the initial-value problem in the canonical Cauchy form, which can be solved by using any well-known step-by-step numerical methods, including the Runge-Kutta methods [33], but the Merson's method is recommended for numerical solving the problem (22) [12, 13].

Discussing the results about the numerical analysis the state of the pipe of a steam superheater

Reducing the initial-boundary-value problem (4)-(7) with the moving boundary (8) to the initial-boundary-value problem (12)-(14), (7) with the fixed boundary (10) allows to significantly simplify the numerical analysis of the state of pipes of steam superheaters considering with the high-temperature creep and the high-temperature corrosion. These simplifications are due to excluding the necessities to rebuild the grid nodes during the integration on the time, but one of the matrices and the vector in the vector-function (22) are the functions of the time due to the moving boundary. Nevertheless, in proposed approach numerical solving the initial-boundary-value problem with moving boundary is maximal similar to the numerical solving the initial-boundary-value problem with the fixed boundary.

Solving the equation (15) with the boundary conditions (16) can be realized not only the method of lines, but using the Galerkin's method for example. Significantly more time requiring for machine-computing the matrices in the vector-function (22) using the Galerkin's method makes the most suitable the method of lines, especially for solving the initial-boundary-value problems with moving boundaries. The band structure of the matrices from the vector function (23), when the method of lines is used, makes this method suitable also, because it is possible computing with only nonzero elements of the band matrices, which will allow to minimize the computing operations.

The result of the vector-function (22) is actually the solution of the system of the linear equations each time with another matrix, corresponding the considered moment of the time. There are a lot well-known methods for solving the systems of linear equations and it is necessary to choose the most suitable of these methods for the considered problem. The possibilities of multiple using the especially transformed matrix of systems of linear equations for solving the linear equations with different given right vectors but with the same matrix like in the LU-method and the Gauss's method are not necessary for building the result of vector-function (22), because the different matrices correspond to the different moments of the time. It seems that the iteration methods, like the Seidel's method, are more suitable for building the result of the vector-function (22) when numerically solving the problem (23).

The Cachanov-Rabotnov damage parameter ω , which included in the mathematical model of the state of pipes of a steam surephaters of boilers, considering the high-temperature creep and the uniform corrosion, will allow to define the time t^* of reaching the limiting state of the pipe using the condition:

$$\exists(0 \leq \rho^* \leq 1) \wedge (t^* > 0): \omega(\rho^*, t^*) = 1, \quad (24)$$

where ρ^* is the normed coordinate of the place-point of forming the macroscopic defect.

Solving the initial-boundary-value problem (10), (12)-(14), (7), representing the mathematical model of the state of pipes of a steam surephaters of boilers, considering the high-temperature creep and the uniform corrosion, will allow to estimate the time, corresponding the limiting state of the pipes, and due to it will give the assessment of workability of the superheater.

Conclusions

It is proposed theoretical estimating workability of steam boilers superheaters on the base of considering the influence of a high-temperature uniform chemical corrosion on of a high-temperature creep of superheater pipes on account of stresses redistributions the pipes walls due to their thickness decreasing.

The high-temperature uniform chemical corrosion is presented by the well-known time and temperature dependences of the height of damaged material. The high-temperature creep is considered using the well-known incremental-type theory taking into account the Cachanov-Rabotnov scalar damage parameter. It is proposed the mathematical model of state of superheaters pipes in the form of initial-boundary-value problem in the domain with the moving boundary. The differential equations, initial and boundary conditions of that problem are corresponded to the well-known in the theory of high-temperature creep. Moving of the boundary is corresponded to the well-known time dependence of the height of damaged material due to the high-temperature uniform chemical corrosion.

Although, the used theory of creep and the used regularities of uniform corrosion are well-known separately, considering the influence of uniform corrosion on the creep is the complicated problem due to the moving boundary in the corresponded initial-boundary-value problem. It is shown, that the spatial variable replacement allows to reduce the proposed initial-boundary-value problem with the moving boundary to the initial-boundary-value problem with the fixed normed boundary, that allows to simplify numerical solving of the considered problem. The method of lines is discussed for solving the initial-boundary-value problem, representing the mathematical model of the state of pipes of superheaters.

References (transliterated)

1. Annaratone D. (2008), *Steam Generators Description and Design*, Springer-Verlag, Berlin Heidelberg, 427 p, ISBN 978-3-540-77714-4.
2. Huang J.-L., Zhou K.-Y., Xu J.-Q., Xu X.-H. and Xie J.-W. (2014), "Failure evaluation of steam-side oxide scales in superheater tubes during unsteady thermal processes: A probabilistic method", *Materials and Corrosion*. vol. 65, is. 12, pp. 1151-1161, <https://doi.org/10.1002/maco.201307338>.
3. Speicher M., Hueggenberg D., Klenk A., Zickler S., Metzger K. (2015), "Materials for Advanced Ultra-Supercritical Fossil-Fuel

- Power Plants: Materials Properties, Microstructure, and Component Behavior", *Energy Technology*, vol. 4, is. 1, pp. 187–192, <https://doi.org/10.1002/ente.201500311>.
4. Movahedi-Rad A., Plasseyed S. S., Attarian M. (2015), "Failure analysis of superheater tube", *Engineering Failure Analysis*, vol. 48, pp. 94–104, <https://doi.org/10.1016/j.engfailanal.2014.11.012>
 5. Tibba G. S., Altenbach H. (2016), "Modelling Creep Behaviour of Superheater Materials", *Energy Procedia*, vol. 93, pp. 197–202, <https://doi.org/10.1016/j.egypro.2016.07.170>.
 6. Abang R., Weiß S., Krautz H. J. (2018), "Impact of increased power plant cycling on the oxidation and corrosion of coal-fired superheater materials", *Fuel*, vol. 220, pp. 521–534, <https://doi.org/10.1016/j.fuel.2018.02.047>.
 7. Timoshenko S. and Goodier J. N. (1947), *Theory of elasticity*, MCGRAW-HILL BOOK COMPANY, Inc., New York Toronto London, 506 p.
 8. Timoshenko S. (1940), *Strength of Materials. Part II: Advanced theory and problems*, D. VAN NOSTRAND COMPANY, Inc., Toronto New York London, 510 p.
 9. Betten J. (2008), *Creep mechanics*, Springer-Verlag. Berlin Heidelberg, 367 p, ISBN 3-540-23204-4.
 10. Lemaitre J., Desmorat R., (2005), *Engineering damage mechanics. Ductile, creep, fatigue and brittle failures*, Springer. Berlin Heidelberg New York, 394 p, ISBN 3-540-21503-4.
 11. Antikayn P. A. (1977), *Korroziya metalla parogeneratorov* [Corrosion of metal of steam generators], Energiya, Moscow, In Russian, 112 p.
 12. Morachkovskii O. K. and Romashov Yu. V. (2009), "Solving initial-boundary-value creep problems", *International Applied Mechanics*, vol. 45, no. 10, pp. 1061–1070, <https://doi.org/10.1007/s10778-010-0247-y>.
 13. Romashov Yu. and Povolotskii E. (2018), "Analysis of the approaches to the assessment of the working capacity of the shells of fuel elements of nuclear power reactors taking into consideration the creepage", *Bulletin of NTU "KhPI". Series: Power and heat engineering processes and equipment*, No. 11(1287), pp. 63–66, ISSN 2078-774X, doi: 10.20998/2078-774X.2018.11.10.
 14. Schiesser W. E. (2017), *Method of Lines Analysis of Turing Models*, World Scientific, New Jersey, 254 p, ISBN 9789813226692.
3. Speicher M., Hueggenberg D., Klenk A., Zickler S., Metzger K. Materials for Advanced Ultra-Supercritical Fossil-Fuel Power Plants: Materials Properties, Microstructure, and Component Behavior. *Energy Technology*. 2015. Vol. 4, Is. 1. P. 187–192. <https://doi.org/10.1002/ente.201500311>.
4. Movahedi-Rad A., Plasseyed S. S., Attarian M. Failure analysis of superheater tube. *Engineering Failure Analysis*. 2015. Vol. 48. P. 94–104. <https://doi.org/10.1016/j.engfailanal.2014.11.012>
 5. Tibba G. S., Altenbach H. Modelling Creep Behaviour of Superheater Materials. *Energy Procedia*. 2016. Vol. 93. P. 197–202. <https://doi.org/10.1016/j.egypro.2016.07.170>.
 6. Abang R., Weiß S., Krautz H. J. Impact of increased power plant cycling on the oxidation and corrosion of coal-fired superheater materials. *Fuel*. 2018. Vol. 220. P. 521–534. <https://doi.org/10.1016/j.fuel.2018.02.047>.
 7. Timoshenko S. and Goodier J. N. *Theory of elasticity*. New York Toronto London: MCGRAW-HILL BOOK COMPANY, Inc., 1947. 506 p.
 8. Timoshenko S. *Strength of Materials. Part II: Advanced theory and problems*. Toronto New York London: D. VAN NOSTRAND COMPANY, Inc., 1940. 510 p.
 9. Betten J. *Creep mechanics*. Berlin Heidelberg: Springer-Verlag, 2008. 367 p. ISBN 3-540-23204-4.
 10. Lemaitre J., Desmorat R. *Engineering damage mechanics. Ductile, creep, fatigue and brittle failures*. Berlin Heidelberg New York: Springer, 2005. 394 p. ISBN 3-540-21503-4.
 11. Антикayн П. А. *Коррозия металла парогенераторов*. Москва: Энергия, 1977. 112 с.
 12. Морачковскій О. К. and Ромашов Ю. В. Solving initial-boundary-value creep problems. *International Applied Mechanics*. 2009. Vol. 45, No. 10. P. 1061–1070. <https://doi.org/10.1007/s10778-010-0247-y>.
 13. Ромашов Ю. В., Поволоцкий Э. В. Анализ подходов к оценке работоспособности оболочек стержневых твэлов энергетических ядерных реакторов с учетом ползучести. *Вісник НТУ «ХПІ». Серія: Енергетичні та теплотехнічні процеси й устаткування*. Харків: НТУ«ХПІ», 2018. № 11(1287). С. 63–66. ISSN 2078-774X. doi: 10.20998/2078-774X.2018.11.10.
 14. Schiesser W. E. *Method of Lines Analysis of Turing Models*. New Jersey: World Scientific, 2017. 254 p. ISBN 9789813226692.

References

1. Annaratone D. *Steam Generators Description and Design*. Berlin Heidelberg: Springer-Verlag, 2008. 427 p. ISBN 978-3-540-77714-4.
2. Huang J.-L., Zhou K.-Y., Xu J.-Q., Xu X.-H. and Xie J.-W. Failure evaluation of steam-side oxide scales in superheater

Поступила (received) 13.01.2019

Відомості про авторів / Сведения об авторах / About the Authors

Єфімов Олександр Вячеславович (Efimov Aleksander) – доктор технічних наук, професор, Національний технічний університет «Харківський політехнічний інститут», завідувач кафедри парогенераторобудування; м Харків, Україна; e-mail: avefim@kpi.kharkov.ua, ORCID: <https://orcid.org/0000-0003-3300-7447>, Scopus: Author ID: 7202040387.

Ромашов Юрій Володимирович (Romashov Yury) – доктор технічних наук, доцент, Національний технічний університет «Харківський політехнічний інститут», професор кафедри парогенераторобудування, Харківський національний університет імені В.Н. Каразіна, професор кафедри прикладної математики; м Харків, Україна; e-mail: yu.v.romashov@gmail.com, ORCID: <https://orcid.org/0000-0001-8376-3510>.

Каверцев Валерій Леонідович (Kavertsev Valerii) – кандидат технічних наук, доцент, Національний технічний університет «Харківський політехнічний інститут», доцент кафедри парогенераторобудування; г. Харків, Україна.